

# SINGLE PITCH

ISOMETRIC VIEW

**PLEASE NOTE**

ALL DETAILS AS SHOWN ARE FOR REFERENCE ONLY AND SUBJECT TO CHANGE PER ACURLITE PROJECT PROPOSAL, SPECIFIC SITE CONDITIONS, ACURLITE P.E. ANALYSIS, AND GOVERNING CODE REQUIREMENTS.



**acurlite**  
Structural Skylights, Inc.

© NOV 30, 2017

570.759.6882 www.acurlite.com sales@acurlite.com

STANDARD  
SYSTEM  
DETAILS

SCALE: N.T.S.

DRAWN BY: K.A.M.

CHECKED BY: C.H.M.

DATE - ISSUE: 11/30/17 - A

SHEET: **SAMPLE**

**OPTIONS FOR VISUAL ENHANCEMENT**

**STANDARD & CUSTOM FINISHES**  
(Paint, Anodize & Powder Coat Available)

**SHADES/LOUVERS - PANELS - BIPV/DYNAMIC GLAZING**  
(Consult Factory For Your Project Specific Requirements)

**VARIABLE SLOPE - ALL PITCHES AVAILABLE**  
(Consult Factory - Based On Project Specific Conditions)

**INSULATED LAMINATED / LAMINATED GLAZING**  
**INCLUDES ALL BACKER ROD & GLAZING SEALANTS**  
(Max Unit Size & Required Thickness - Per AAMA Guidelines)  
(Glazing Calculations Provided For Additional Cost)

**EXTRUDED ALUM. COVER CAP & PRESSURE CAP W/ GASKET**

**ALUM. GLASS REST & SILICONE SETTING BLOCK**  
(Located At Quarter Points - 2 Per Bay)

**SILICONE GASKET**

**STRUCTURAL SEAL FLANGE - IF REQUIRED**  
(Factory Applied To Purlin - 1/4-20 x 3/4" Flat Head Screw)

**EXTRUDED ALUMINUM PURLIN**  
(2 1/2" Width - Depth/Reinforcement Per Acurlite P.E. Analysis)

**EXTRUDED ALUMINUM RAFTER**  
(2 1/2" Width - Depth/Reinforcement Per Acurlite P.E. Analysis)

**OPTIONS FOR THERMAL ENHANCEMENT**

**DETAILS AS SHOWN ARE TYPICAL & FOR REFERENCE**  
(Consult Factory for Additional Modification & Performance Improvements)

**INSULATED CLOSURE - FOR ADDITIONAL COST**  
(Factory Assembly Includes Rigid Insulation & Formed Backer)

**MINERAL WOOL TO FILL VOIDS - FOR ADDITIONAL COST**  
(Standard Batt Type - Installer To Ensure System Weep Path Is NOT Blocked)

**SILL LUG**

(Lug Size, Type & Locations Per Acurlite P.E. Analysis)

**FORMED EXTERIOR CLOSURE - 1/16" ALUM. STANDARD**  
(Consult Factory For Optional Thickness & Materials)  
(Typical Splice Shown As Dashed Line - Locate As Required)

**FORMED SILL PAN - 1/16" ALUM. STANDARD**  
(Consult Factory For Optional Thickness & Materials)

**SPONGE GASKET - FACTORY APPLIED TO SILL PAN**  
(3/4" Void At System Weep As Required)

**CURB / SUBSTRUCTURE BY OTHERS**

**DETAILS / MATERIALS PER CONTRACT DOCUMENTS**  
(Not By Acurlite - Provided By Others)

**ISOLATION/WATERPROOF MEMBRANE**  
(Not By Acurlite - Provided By Others)

**PROPER SUBSTRATE REQUIRED FOR ATTACHMENT**  
(Not By Acurlite - Provided By Others)

**INSTALLATION**

**FASTENERS PROVIDED BY ACURLITE**  
(Fastener Size & Type Per Acurlite P.E. Analysis Unless Noted)

**INSTALL GLAZING PER INDUSTRY STANDARDS**  
(Follow GANA Guidelines & Acurlite Installation Manual)

**USE SPECIFIED DOW CORNING SILICONE**  
(Per Acurlite P.E. Analysis & Installation Manual)

**SNAP ON COVER CAP**  
(Not Required For Water Tightness)

**FASTEN PRESSURE CAP TO RAFTER & APPLY SEAL**

**BACKER ROD & CONTINUOUS SEAL**

**APPLY CONT. STRUCTURAL SEAL - IF REQUIRED**

**FASTEN EXTERIOR CLOSURE TO PURLIN / FLANGE**

**FASTEN PURLIN ASSEMBLY TO RAFTER**

**FASTEN EXTERIOR CLOSURE TO SILL PAN**  
(Use #10 x 1/2" Pan Head S.M.S. - Locate 12" O.C. Typical)

**FASTEN RAFTER ASSEMBLY TO LUGS - IF REQ.**

**FASTEN SILL LUG TO CURB**

(Seal In & Around Lug & Fastener)

**FULL BEARING SHIM - IF REQUIRED**

(1/4" Max. Shim Space Typical - Unless Noted Otherwise)  
(Not by Acurlite - Provided By Others)

**INSTALL SILL PAN IN BED OF SEALANT**

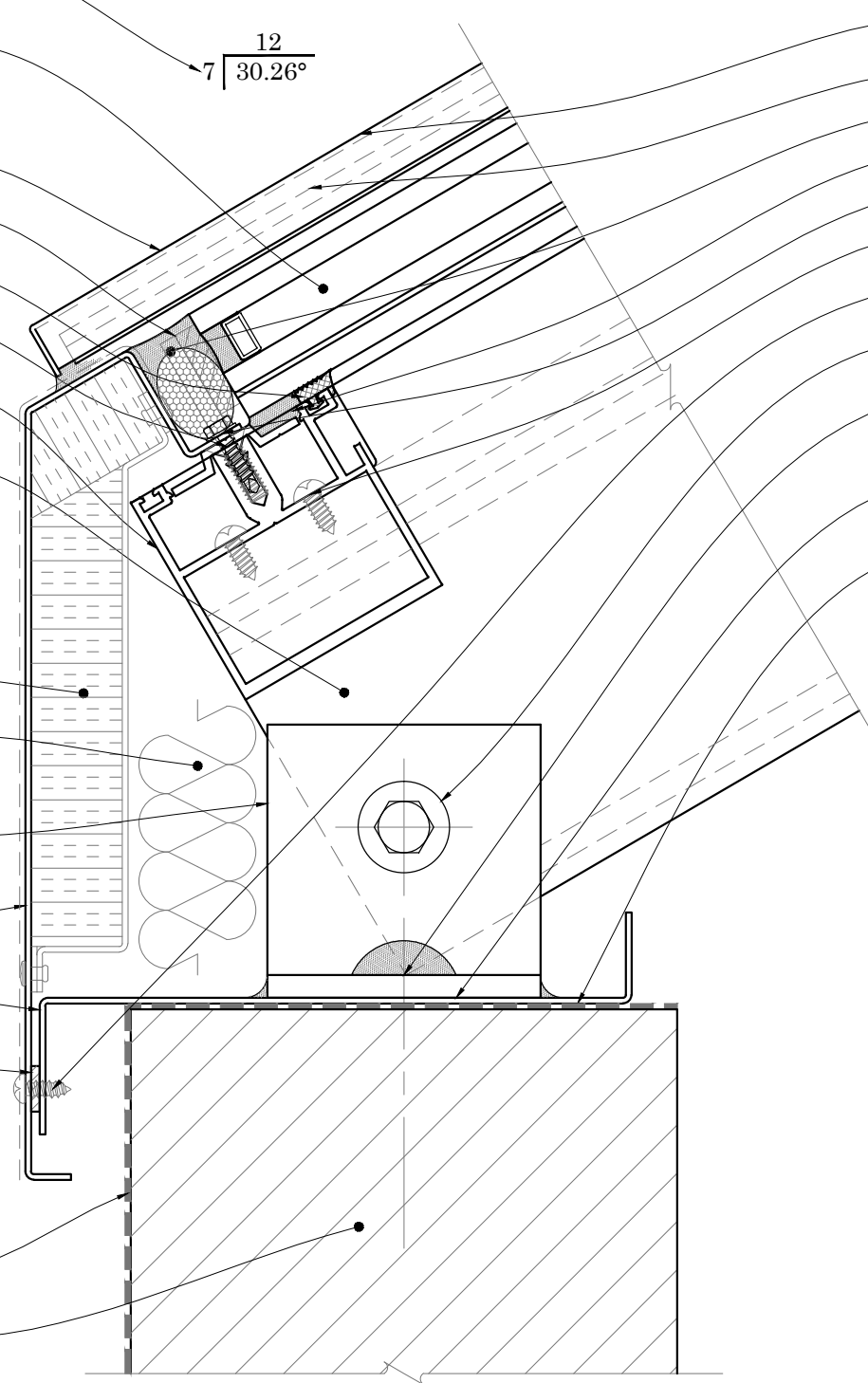

**PLEASE NOTE**

**CURB MUST RESIST ALL LOADS/REACTIONS IMPOSED BY SKYLIGHT**  
(Reactions Provided By Acurlite P.E.)  
(Responsible E.O.R. to Verify and Approve)

**CURB SHOULD BE PLUMB, LEVEL & SQUARE PER INDUSTRY STANDARD TOLERANCES**  
(Max Allowed ±1/8" PER 12' - 0" - Unless Noted Otherwise)  
(Not By Acurlite - Provided By Others)

**ALL ROOFING, TERMINATION BARS, REGLETS, COUNTER FLASHINGS & FLASHINGS NOT INTEGRAL TO SKYLIGHT SYSTEM FUNCTION**  
(Not By Acurlite - Provided By Others)

**D1 SILL TYPICAL DETAIL**

**PLEASE NOTE**

ALL DETAILS AS SHOWN ARE FOR REFERENCE ONLY AND SUBJECT TO CHANGE PER ACURLITE PROJECT PROPOSAL, SPECIFIC SITE CONDITIONS, ACURLITE P.E. ANALYSIS, AND GOVERNING CODE REQUIREMENTS.

© NOV 30, 2017  
570.759.6882 www.acurlite.com sales@acurlite.com

**acurlite**  
Structural Skylights, Inc.

**STANDARD SYSTEM DETAILS**

SCALE:	6" = 1' - 0"
DRAWN BY:	K.A.M.
CHECKED BY:	C.H.M.
DATE - ISSUE:	11/30/17 - A
SHEET:	D1

**OPTIONS FOR VISUAL ENHANCEMENT**

**STANDARD & CUSTOM FINISHES**  
(Paint, Anodize & Powder Coat Available)

**SHADES/LOUVERS - PANELS - BIPV/DYNAMIC GLAZING**  
(Consult Factory For Your Project Specific Requirements)

**VARIABLE SLOPE - ALL PITCHES AVAILABLE**  
(Consult Factory - Based On Project Specific Conditions)

**INSULATED LAMINATED / LAMINATED GLAZING**  
**INCLUDES ALL BACKER ROD & GLAZING SEALANTS**  
(Max Unit Size & Required Thickness - Per AAMA Guidelines)  
(Glazing Calculations Can Be Provided For Additional Cost)

**ALUM. GLASS REST & SILICONE SETTING BLOCK**  
(Located At Quarter Points - 2 Per Bay)

**STRUCTURAL SEAL FLANGE FASTENED TO PURLIN**  
(Factory Applied To Purlin - 1/4-20 x 3/4" Flat Head Screw)

**SILICONE GASKET**

**EXTRUDED ALUM. PURLIN**  
(2 1/2" Width - Depth/Reinforcement Per Acurlite P.E. Analysis)

**EXTRUDED ALUM. RAFTER**  
(2 1/2" Width - Depth/Reinforcement Per Acurlite P.E. Analysis)

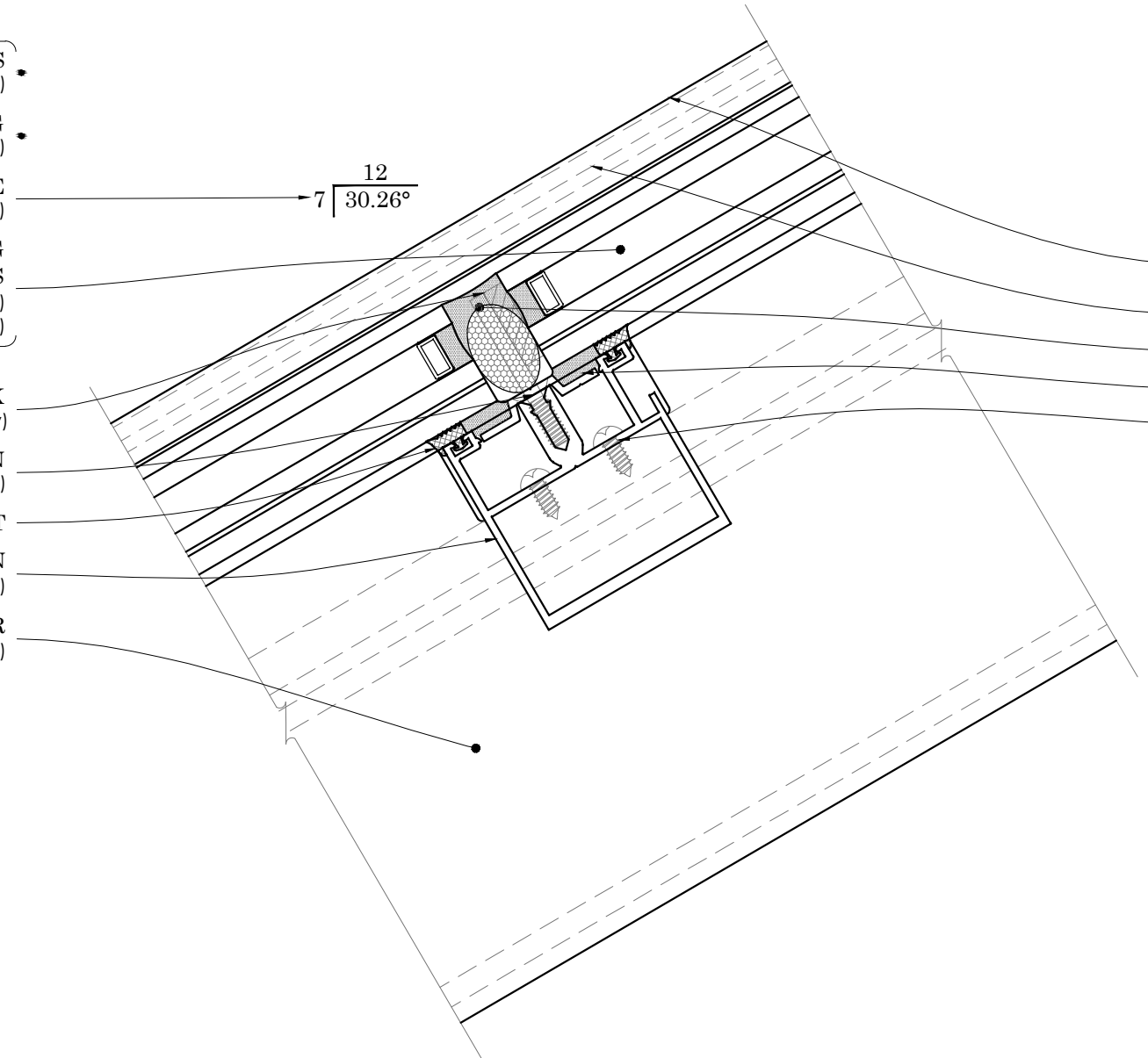

**INSTALLATION**

**FASTENERS PROVIDED BY ACURLITE**  
(Fastener Size & Type Per Acurlite P.E. Analysis Unless Noted)

**INSTALL GLAZING PER INDUSTRY STANDARDS**  
(Follow GANA Guidelines & Acurlite Installation Manual)

**USE SPECIFIED DOW CORNING SILICONE**  
(Per Acurlite P.E. Analysis & Installation Manual)

**SNAP ON COVER CAP**  
(Not Required For Water Tightness)

**FASTEN PRESSURE CAP TO RAFTER & APPLY SEAL**

**BACKER ROD & CONTINUOUS SEAL**

**APPLY CONT. STRUCTURAL SEAL - IF REQUIRED**

**FASTEN PURLIN ASSEMBLY TO RAFTER**

**D2 PURLIN TYPICAL DETAIL**

**PLEASE NOTE**

ALL DETAILS AS SHOWN ARE FOR REFERENCE ONLY AND SUBJECT TO CHANGE PER ACURLITE PROJECT PROPOSAL, SPECIFIC SITE CONDITIONS, ACURLITE P.E. ANALYSIS, AND GOVERNING CODE REQUIREMENTS.

© NOV 30, 2017  
570.759.6882 www.acurlite.com sales@acurlite.com

**STANDARD SYSTEM DETAILS**

SCALE:	6" = 1' - 0"
DRAWN BY:	K.A.M.
CHECKED BY:	C.H.M.
DATE - ISSUE:	11/30/17 - A
SHEET:	D2

**INSTALLATION**

- FASTENERS PROVIDED BY ACURLITE  
(Fastener Size & Type Per Acurlite P.E. Analysis Unless Noted)
- INSTALL GLAZING PER INDUSTRY STANDARDS  
(Follow GANA Guidelines & Acurlite Installation Manual)
- USE SPECIFIED DOW CORNING SILICONE  
(Per Acurlite P.E. Analysis & Installation Manual)
- SNAP ON COVER CAP  
(Not Required For Water Tightness)
- FASTEN PRESSURE CAP TO RAFTER & APPLY SEAL
- BACKER ROD & CONTINUOUS SEAL
- FASTEN EXTERIOR CLOSURE TO PURLIN / FLANGE
- APPLY CONT. STRUCTURAL SEAL - IF REQUIRED
- FASTEN PURLIN ASSEMBLY TO RAFTER
- FASTEN RAFTER ASSEMBLY TO LUGS - IF REQ.
- FASTEN EXTERIOR CLOSURE TO SILL PAN  
(Use #10 x 1/2" Pan Head S.M.S. - Locate 12" O.C. Typical)
- FASTEN LUG TO CURB & SEAL  
(Seal In & Around Lug & Fastener)
- FULL BEARING SHIM AS REQUIRED  
(1/4" Max. Shim Space Typical - Unless Noted Otherwise)  
(Not by Acurlite - Provided By Others)
- INSTALL SILL PAN IN BED OF SEALANT

**PLEASE NOTE**

- CURB MUST RESIST ALL LOADS/REACTIONS IMPOSED BY SKYLIGHT  
(Reactions Provided By Acurlite P.E.)  
(Responsible E.O.R. to Verify and Approve)
- CURB SHOULD BE PLUMB, LEVEL & SQUARE PER INDUSTRY STANDARD TOLERANCES  
(Max Allowed ±1/8" PER 12' - 0" - Unless Noted Otherwise)  
(Not By Acurlite - Provided By Others)
- ALL ROOFING, TERMINATION BARS, REGLETS, COUNTER FLASHINGS & FLASHINGS NOT INTEGRAL TO SKYLIGHT SYSTEM FUNCTION  
(Not By Acurlite - Provided By Others)

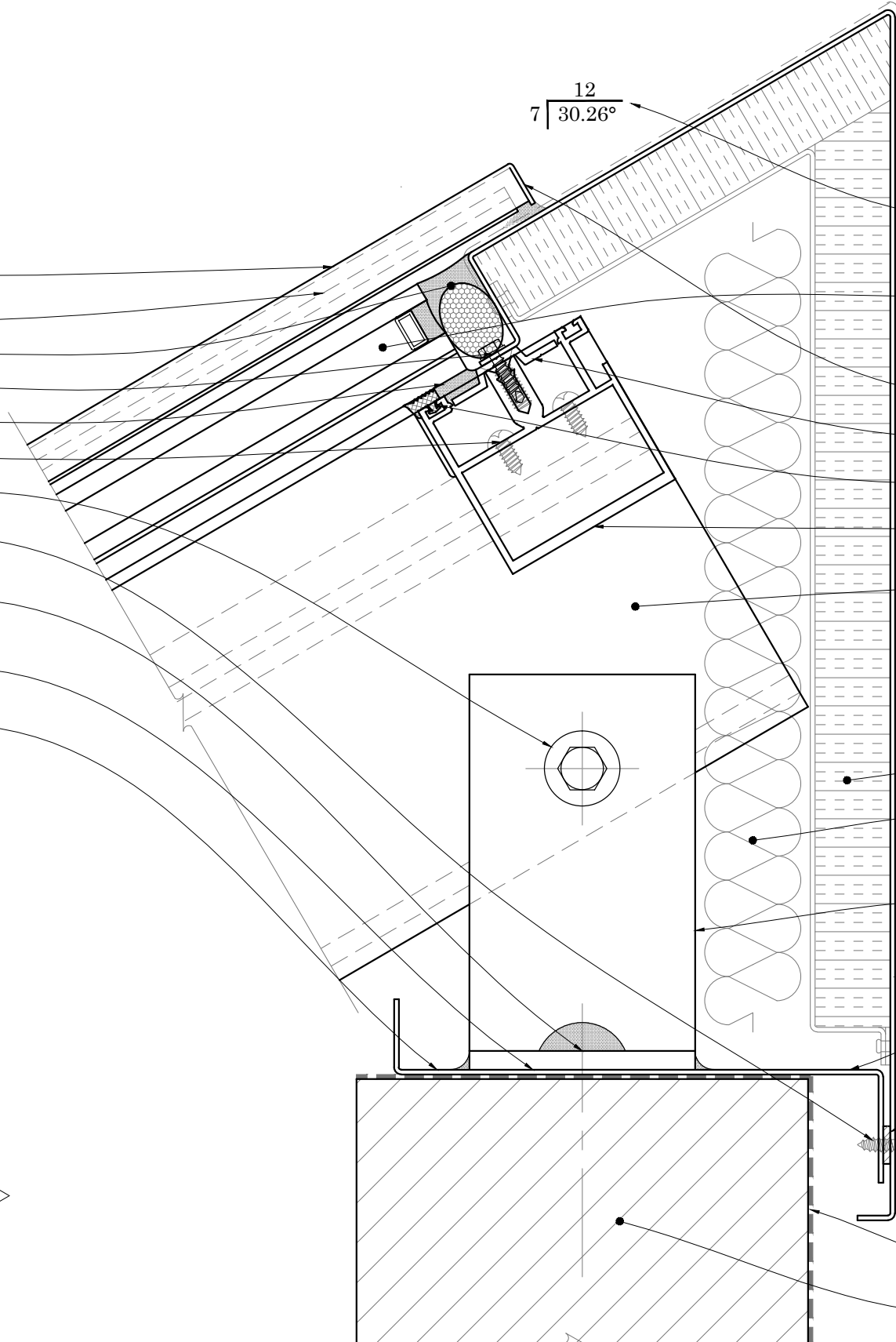

**OPTIONS FOR VISUAL ENHANCEMENT**

- STANDARD & CUSTOM FINISHES  
(Paint, Anodize & Powder Coat Available)
- SHADES/LOUVERS - PANELS - BIPV/DYNAMIC GLAZING  
(Consult Factory For Your Project Specific Requirements)
- VARIABLE SLOPE - ALL PITCHES AVAILABLE  
(Consult Factory - Based On Project Specific Conditions)
- INSULATED LAMINATED / LAMINATED GLAZING  
INCLUDES ALL BACKER ROD & GLAZING SEALANTS  
(Max Unit Size & Required Thickness - Per AAMA Guidelines)  
(Glazing Calculations Provided For Additional Cost)

- EXTRUDED ALUM. COVER CAP & PRESSURE CAP W/ GASKET
- STRUCTURAL SEAL FLANGE - IF REQUIRED  
(Factory Applied To Purlin - 1/4-20 x 3/4" Flat Head Screw)
- SILICONE GASKET
- EXTRUDED ALUMINUM PURLIN  
(2 1/2" Width - Depth/Reinforcement Per Acurlite P.E. Analysis)
- EXTRUDED ALUMINUM RAFTER  
(2 1/2" Width - Depth/Reinforcement Per Acurlite P.E. Analysis)

**OPTIONS FOR THERMAL ENHANCEMENT**

- DETAILS AS SHOWN ARE TYPICAL & FOR REFERENCE  
(Consult Factory for Additional Modification & Performance Improvements)
- INSULATED CLOSURE - FOR ADDITIONAL COST  
(Factory Assembly Includes Rigid Insulation & Formed Backer)
- MINERAL WOOL TO FILL VOIDS - FOR ADDITIONAL COST  
(Standard Batt Type - Installer To Ensure System Weep Path Is NOT Blocked)

- RIDGE LUG  
(Lug Size, Type & Locations Per Acurlite P.E. Analysis)
- FORMED EXTERIOR CLOSURE - 1/16" ALUM. STANDARD  
(Consult Factory For Optional Thickness & Materials)  
(Typical Splice Shown As Dashed Line - Locate As Required)
- FORMED SILL PAN - 1/16" ALUM. STANDARD  
(Consult Factory For Optional Thickness & Materials)
- SPONGE GASKET - FACTORY APPLIED TO SILL PAN  
(3/4" Void At System Weep As Required)

**CURB / SUBSTRUCTURE BY OTHERS**

- DETAILS / MATERIALS PER CONTRACT DOCUMENTS  
(Not By Acurlite - Provided By Others)
- ISOLATION/WATERPROOF MEMBRANE  
(Not By Acurlite - Provided By Others)
- PROPER SUBSTRATE REQUIRED FOR ATTACHMENT  
(Not By Acurlite - Provided By Others)

**D3** **RIDGE**  
TYPICAL DETAIL

**PLEASE NOTE**

ALL DETAILS AS SHOWN ARE FOR REFERENCE ONLY AND SUBJECT TO CHANGE PER ACURLITE PROJECT PROPOSAL, SPECIFIC SITE CONDITIONS, ACURLITE P.E. ANALYSIS, AND GOVERNING CODE REQUIREMENTS.



**acurlite**  
Structural Skylights, Inc.  
www.acurlite.com sales@acurlite.com

© NOV 30, 2017

570.759.6882

**STANDARD SYSTEM DETAILS**

SCALE:  
6" = 1' - 0"

DRAWN BY:  
K.A.M.

CHECKED BY:  
C.H.M.

DATE - ISSUE:  
11/30/17 - A

SHEET:  
D3

**OPTIONS FOR VISUAL ENHANCEMENT**

- **STANDARD & CUSTOM FINISHES**  
(Paint, Anodize & Powder Coat Available)
- **SHADES/LOUVERS - PANELS - BIPV/DYNAMIC GLAZING**  
(Consult Factory for your project specific needs)
- **VARIABLE SLOPE - ALL PITCHES AVAILABLE**  
(Consult Factory - Based On Project Specific Conditions)
- **INSULATED LAMINATED / LAMINATED GLAZING**  
**INCLUDES ALL BACKER ROD & GLAZING SEALANTS**  
(Max Unit Size & Required Thickness - Per AAMA Guidelines)  
(Glazing Calculations Can Be Provided For Additional Cost)
- **EXTRUDED ALUM. COVER CAP & PRESSURE CAP W/ GASKET**
- **SILICONE GASKET**
- **EXTRUDED ALUM. PURLIN**  
(2 1/2" Width - Depth/Reinforcement Per Acurlite P.E. Analysis)
- **EXTRUDED ALUM. RAFTER**  
(2 1/2" Width - Depth/Reinforcement Per Acurlite P.E. Analysis)

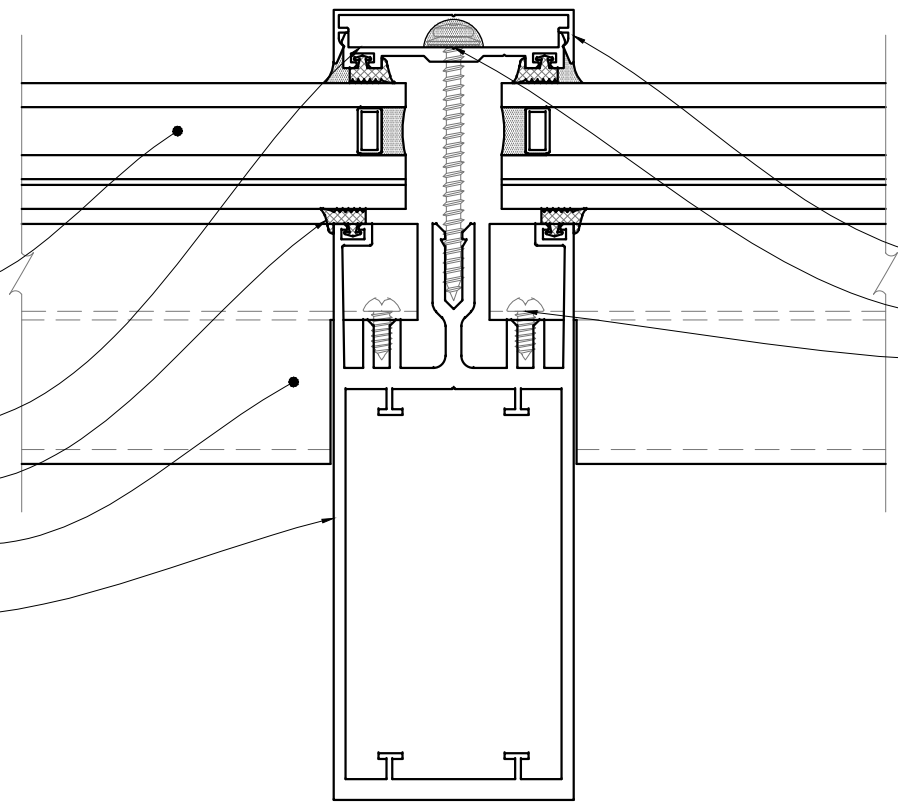

**INSTALLATION**

- **FASTENERS PROVIDED BY ACURLITE**  
(Fastener Size & Type Per Acurlite P.E. Analysis Unless Noted)
- **INSTALL GLAZING PER INDUSTRY STANDARDS**  
(Follow GANA Guidelines & Acurlite Installation Manual)
- **USE SPECIFIED DOW CORNING SILICONE**  
(Per Acurlite P.E. Analysis & Installation Manual)
- **SNAP ON COVER CAP**  
(Not Required for Water tightness)
- **FASTEN PRESSURE CAP TO RAFTER & APPLY SEAL**
- **FASTEN PURLIN ASSEMBLY TO RAFTER**

**D4** **RAFTER**  
**TYPICAL DETAIL**

**PLEASE NOTE**

ALL DETAILS AS SHOWN ARE FOR REFERENCE ONLY AND SUBJECT TO CHANGE PER ACURLITE PROJECT PROPOSAL, SPECIFIC SITE CONDITIONS, ACURLITE P.E. ANALYSIS, AND GOVERNING CODE REQUIREMENTS.



**acurlite**  
**Structural Skylights, Inc.**  
www.acurlite.com sales@acurlite.com

© NOV 30, 2017

570.759.6882

**STANDARD SYSTEM DETAILS**

SCALE:  
**6" = 1' - 0"**

DRAWN BY:  
**K.A.M.**

CHECKED BY:  
**C.H.M.**

DATE - ISSUE:  
**11/30/17 - A**

SHEET:  
**D4**

**INSTALLATION**

- FASTENERS PROVIDED BY ACURLITE  
(Fastener Size & Type Per Acurlite P.E. Analysis Unless Noted)
- INSTALL GLAZING PER INDUSTRY STANDARDS  
(Follow GANA Guidelines & Acurlite Installation Manual)
- USE SPECIFIED DOW CORNING SILICONE  
(Per Acurlite P.E. Analysis & Installation Manual)
- SNAP ON COVER CAP  
(Not Required For Water Tightness)
- FASTEN PRESSURE CAP TO RAFTER & APPLY SEAL
- FASTEN EXTERIOR CLOSURE TO RAFTER
- FASTEN PURLIN ASSEMBLY TO RAFTER
- FASTEN EXTERIOR CLOSURE TO SILL PAN  
(Use #10 x 1/2" Pan Head S.M.S. - Locate 12" O.C. Typical)
- INSTALL SILL PAN IN BED OF SEALANT

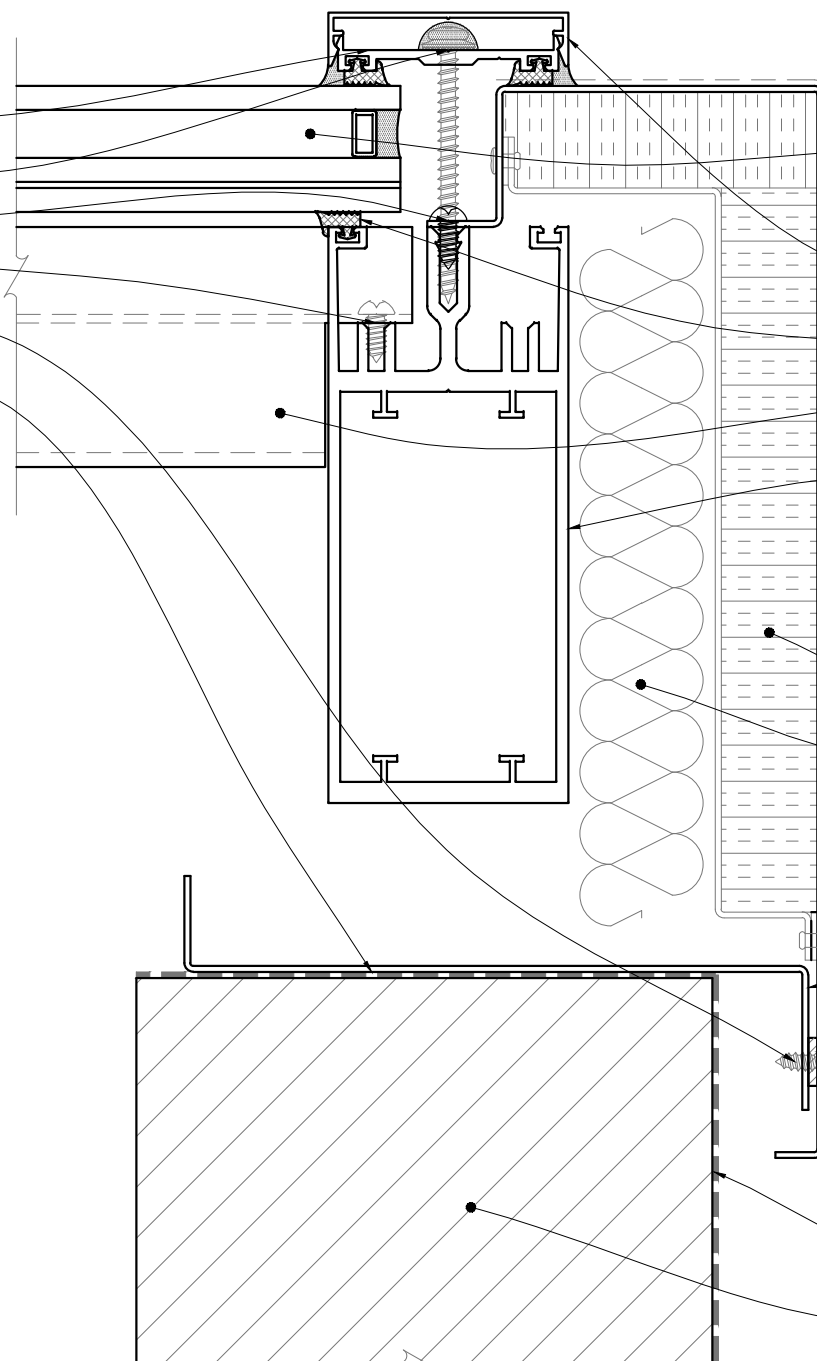

**OPTIONS FOR VISUAL ENHANCEMENT**

- STANDARD & CUSTOM FINISHES  
(Paint, Anodize & Powder Coat Available)
- SHADES/LOUVERS - PANELS - BIPV/DYNAMIC GLAZING  
(Consult Factory For Your Project Specific Requirements)
- VARIABLE SLOPE - ALL PITCHES AVAILABLE  
(Consult Factory - Based On Project Specific Conditions)
- INSULATED LAMINATED / LAMINATED GLAZING  
INCLUDES ALL BACKER ROD & GLAZING SEALANTS  
(Max Unit Size & Required Thickness - Per AAMA Guidelines)  
(Glazing Calculations Can Be Provided For Additional Cost)

- EXTRUDED ALUM. COVER CAP & PRESSURE CAP W/ GASKET
- SILICONE GASKET
- EXTRUDED ALUM. PURLIN  
(2 1/2" Width - Depth/Reinforcement Per Acurlite P.E. Analysis)
- EXTRUDED ALUM. RAFTER  
(2 1/2" Width - Depth/Reinforcement Per Acurlite P.E. Analysis)

**OPTIONS FOR THERMAL ENHANCEMENT**

- DETAILS AS SHOWN ARE TYPICAL & FOR REFERENCE  
(Consult Factory for Additional Modification & Performance Improvements)
- INSULATED CLOSURE - FOR ADDITIONAL COST  
(Factory Assembly Includes Rigid Insulation & Formed Alum. Backer)
- MINERAL WOOL TO FILL VOIDS - FOR ADDITIONAL COST  
(Standard Batt Type - Installer To Ensure System Weep Path Is NOT Blocked)

- FORMED EXTERIOR CLOSURE - 1/16" ALUM. STANDARD  
(Consult Factory For Optional Thickness & Materials)  
(Typical Splice Shown As Dashed Line - Locate As Required)
- FORMED SILL PAN - 1/16" ALUM. STANDARD  
(Consult Factory For Optional Thickness & Materials)
- PSA SPONGE GASKET - APPLIED TO SILL PAN  
(3/4" Void At System Weep As Required)

**CURB / SUBSTRUCTURE BY OTHERS**

- DETAILS / MATERIALS PER CONTRACT DOCUMENTS  
(Not By Acurlite - Provided By Others)
- ISOLATION/WATERPROOF MEMBRANE  
(Not By Acurlite - Provided By Others)
- PROPER SUBSTRATE REQUIRED FOR ATTACHMENT  
(Not By Acurlite - Provided By Others)

**PLEASE NOTE**

- CURB MUST RESIST ALL LOADS/REACTIONS IMPOSED BY SKYLIGHT  
(Reactions Provided By Acurlite P.E.)  
(Responsible E.O.R. to Verify and Approve)
- CURB SHOULD BE PLUMB, LEVEL & SQUARE PER INDUSTRY STANDARD TOLERANCES  
(Max Allowed ±1/8" PER 12' - 0" - Unless Noted Otherwise)  
(Not By Acurlite - Provided By Others)
- ALL ROOFING, TERMINATION BARS, REGLETS, COUNTER FLASHINGS & FLASHINGS NOT INTEGRAL TO SKYLIGHT SYSTEM FUNCTION  
(Not By Acurlite - Provided By Others)

**D5** JAMB TYPICAL DETAIL

**PLEASE NOTE**

ALL DETAILS AS SHOWN ARE FOR REFERENCE ONLY AND SUBJECT TO CHANGE PER ACURLITE PROJECT PROPOSAL, SPECIFIC SITE CONDITIONS, ACURLITE P.E. ANALYSIS, AND GOVERNING CODE REQUIREMENTS.

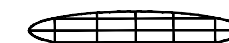

**acurlite**  
Structural Skylights, Inc.  
www.acurlite.com sales@acurlite.com

© NOV 30, 2017

570.759.6882

**STANDARD SYSTEM DETAILS**

SCALE:  
6" = 1' - 0"

DRAWN BY:  
K.A.M.

CHECKED BY:  
C.H.M.

DATE - ISSUE:  
11/30/17 - A

SHEET:  
D5