



# NATIONAL CERTIFIED TESTING LABORATORIES

FIVE LEIGH DRIVE • YORK, PENNSYLVANIA 17406 • TELEPHONE (717) 846-1200  
FAX (717) 767-4100  
www.nctlinc.com

## Simulation Performance, Solar Heat Gain Coefficient, Visible Transmittance and Condensation Resistance Calculation Report

**REPORT NO:** NCTL-110-14352-01  
**SIMULATION DATE:** 11/18/11  
**REPORT DATE:** 11/18/11

**Client:** Acurlite Structural Skylights  
1015 North Vine St., PO Box 5  
Berwick, PA 18603

**Product Line:** Acurlite Structural Skylights' "Skylight" Aluminum Sloped Skylight

**Specification:** NFRC 100-2010: "Procedure for Determining Fenestration Product U-Factors".  
NFRC 200-2010: "Procedure for Determining Fenestration Product Solar Heat  
Gain Coefficients and Visible Transmittance at Normal Incidence".  
NFRC 500-2010: "Procedure for Determining Fenestration Product  
Condensation Resistance Values".  
Therm 6.x / Window 6.x NFRC Simulation Manual (Approved at test date)

**Procedures  
and  
Compliance:** All U-factor, Solar Heat Gain Coefficients, Visible Transmittance and  
Condensation Resistance values were calculated using the following  
characteristics: a default value of 0.30 solar absorptance for all products other  
than window glazed wall and sloped glazing which have a solar absorptance of  
0.50. The best glazing option was used as the configuration for SHGC and VT  
specialty products table. NCTL is a NFRC accredited simulation laboratory and  
this simulation was conducted in full compliance with NFRC requirements. This  
report does not constitute an opinion or endorsement by the laboratory. Ratings  
values included in this report are for submittal to an NFRC-licensed IA and are  
not meant to be used directly for labeling purposes. Only those values identified  
on a valid Certification Authorization Report (CAR) by an NFRC accredited  
Inspection Agency (IA) are to be used for labeling purposes. Rounding per NFRC  
601-2010: "NFRC Unit and Measurement Policy".

### PRODUCT LINE DESCRIPTION

**General:** The product line modeled is Acurlite Structural Skylights' "Skylight" Aluminum  
Sloped Skylight.

**Model Size Simulations:** 2000mm x 2000mm (78.740" x 78.740")

**Weatherseals:** Not applicable

**Gas Fillings:**

Gas Type	Filling Technique	Percentage
Argon	Single probe	90%

**Reinforcement:** Not applicable.

**Edge – of - Glass – Construction:** Head and Sill frame sections are structurally glazed. Jamb and Meeting Stile are Compression glazed.

**Finish:** Painted Aluminum, Anodized Aluminum

**Frame Description:**

Code	Type	Definition
AU	Aluminum Improved	All members are thermally improved

**Sash Description:**

Code	Type	Definition
N	Not applicable	Product component does not require a code

**Spacer and Sealant:**

Code	Type	Definition
A1-D	Aluminum	Aluminum spacer system
S5-D	Steel Reinforced Butyl	Butyl spacer material with stainless steel substrate.

**Group Leaders:** The following group leaders are actual simulated individual products per NFRC 4.2.4 and the NFRC Technical Interpretations where applicable. All remaining individual products' U-factors in the corresponding groups are represented by the group leader's U-factor.

**Frame Group Leader:** Determined by NFRC 100-2010 Section 4.2.4.5.

Frame ID	Frame Description	U <sub>FRAME</sub>
A	Painted Aluminum	0.455*
B	Anodized Aluminum	0.454

\* Group Leader

**Modeling Assumptions and Comments Deemed Important:****Sealing Rules:**

All cavities that are opened to the exterior within a frame section shall be modeled according to ISO 15099, Section 6.7.1, which states that cavities greater than 2mm but equal to or less than 10 mm shall be modeled as “slightly ventilated air cavities”. For physical testing purposes the product is sealed at the inside surface with tape or equivalent to prevent air infiltration. Air cavities created by this sealing technique must be simulated with the standard NFRC “Frame Cavity” material. If cavities on the frame are sealed (covered) to the surround panel with tape or equivalent, those cavities are also filled with NFRC “Frame Cavity” material within the simulation model. If the frame is not covered or sealed, those areas are left hollow or opened within the simulation model.

**Continuous elements:**

All elements continuous within the product line are identified from the Bill-of-Materials and detailed drawings via the referenced dimensions and cut lengths as compared to the overall size of the product.

**General Notes:**

The Condensation Resistance results obtained from this procedure are for controlled laboratory conditions and do not include the effects of air movement through the specimen, solar radiation, and the thermal bridging that may occur due to the specific design and construction of the fenestration system opening.

**Miscellaneous assumptions:**

1. The screen extrusions were not modeled.
2. All radii are simulated at angles.
3. Any spacer simulated using a spacer system from the Frame Spacer Library match the required configurations for this manufacturer’s spacer system.
4. The modeling was performed in accordance with the manufacturer’s assembly drawing from a DXF file.

**Component Area and Frame Heights:**

Frame heights, calculated areas, area weighted values for U-factor, SHGC, and VT, and center –of-glazing are located in approved NFRC simulation programs for all individual products.

**NCTL Therm Section Filename Methodology**

Filename Codes Example: HD-CU-D-F1_003.THM	
HD	Frame Section (Head)
CU-D	Spacer (Intercept)
F1	Frame Description
_003	Glazing ID #3

A baseline product test in accordance with the "NFRC 102: Test Procedure for Measuring the Steady-State Thermal Transmittance of Fenestration Systems" is required in order to validate the "Model Size Matrix of U-Values" as previously indicated. Per Section 1.4.3 of NFRC 100-2010, "the baseline product is the individual product selected for validation testing". **The individual product selected as the baseline product shall be the lowest simulated individual product or an individual product having a simulated U-factor within 0.60 W/ (m<sup>2</sup>\*K) (0.10 BTU/HR/ft<sup>2</sup>/°F) or 20% of the listed lowest simulated U-factor.**

**Note:**

1. For lowest U-factor listings where multiple individual products are shown, validation testing can be conducted on any of the configurations listed.
2. Actual simulated individual products are required for product line validation testing.
3. All individual products in the product line were simulated using the approved NFRC THERM program.

For the purposes of validation testing, production line units and sizes shall be used to represent the baseline products. Representative sizes are therefore defined as the production sizes with the least deviation (D) from the model sizes, calculated per NFRC 100. The previously listed model sizes shall be used for baseline product validation testing.

Copies of this report and the detailed product drawings will be retained by NCTL for a period of four (4) years. This report may not be reproduced, except in full, without the approval of NCTL. The results only to the fenestration product simulated. The attached diskette(s) contain(s) all required NFRC data and software files.

**NATIONAL CERTIFIED TESTING LABORATORIES**

Performed by:

Reviewed by:

**CHRISTIAN J. MITCHELL**  
NFRC Accredited Simulator

**STEVEN H. COBLE**  
NFRC Accredited Simulator  
Simulator-In-Responsible-Charge

Attachments

**Report Log**

**Product Line:** *Acurlite Structural Skylights' "Skylight" Aluminum Sloped Skylight*

**Date:**  
*11/18/11* - *Original Report issued to Acurlite Structural Skylights and Inspection Agency*

***ATTACHMENT A***

***Product Drawings***

TEST SPECIMEN COMPLIES  
WITH THESE DETAILS.  
ANY DEVIATION IS NOTED.

NCTL-110-14352-01

TEST COMPLETE: 11/18/11

Acurlite Structural Skylights

Part	Number	Material
4" Rafter	H-07833	Painted or Anodized Aluminum
Head / Sill Frame	S-31713	Painted or Anodized Aluminum
Snap Cover	S-08545	Painted or Anodized Aluminum
Pressure Cap	S-35591	Painted or Anodized Aluminum
Frame Spacer	S-38970	Painted or Anodized Aluminum

TEST SPECIMEN COMPLIES  
WITH THESE DETAILS.  
ANY DEVIATION IS NOTED.  
NCTL: 110-14352-01  
TEST COMPLETE: 11/18/11

CS-1  
SK-1

4'-0 1/4"  
OUT TO OUT OF FLASHING  
**PLAN VIEW**  
SCALE : 3" = 1'-0"

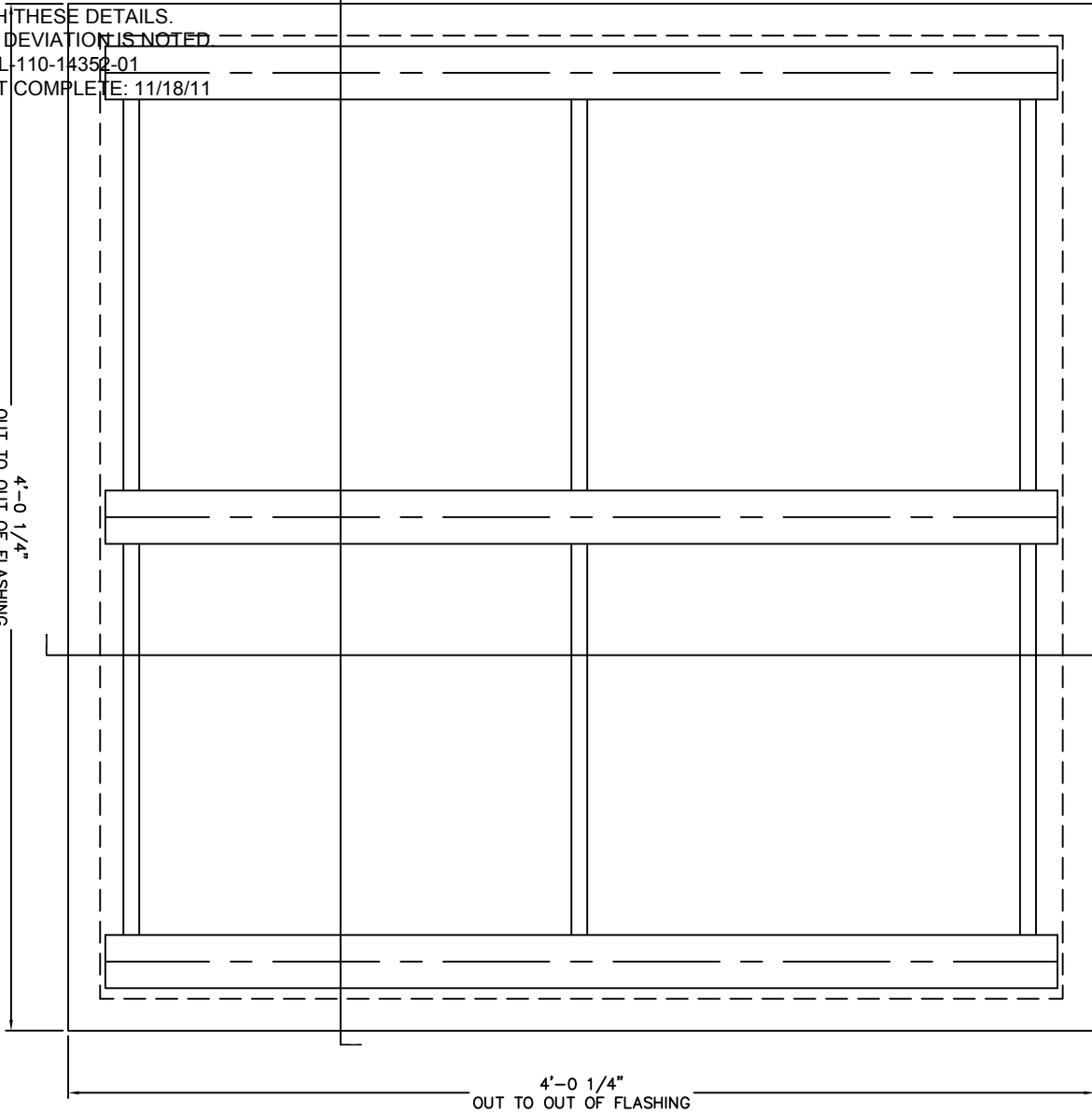

**CROSS SECTION CS-1**  
SCALE : 3" = 1'-0"

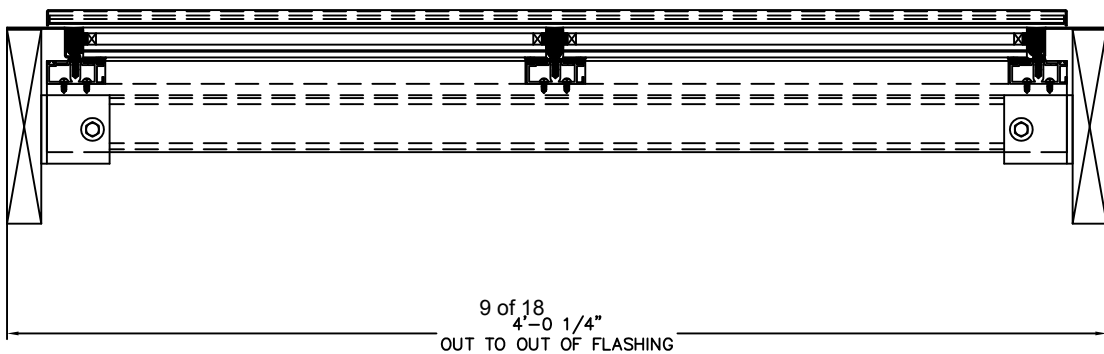



TEST SPECIMEN COMPLIES  
WITH THESE DETAILS.  
ANY DEVIATION IS NOTED:  
NCTL-110-14352-01  
TEST COMPLETE: 11/18/11

CS-1  
SK-1

CS-2  
SK-1

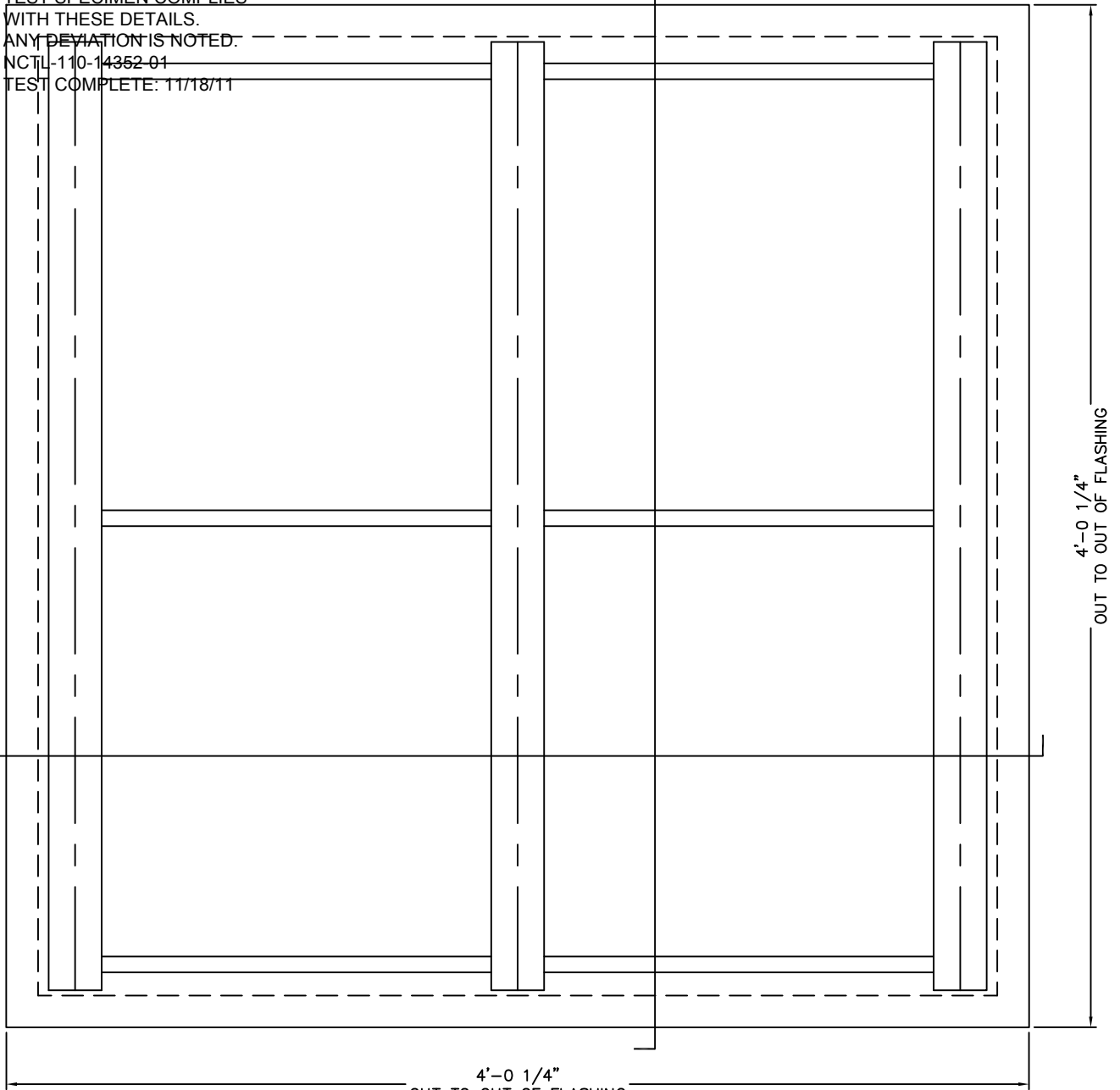

4'-0 1/4"  
OUT TO OUT OF FLASHING

**PLAN VIEW**

SCALE : 3" = 1'-0"

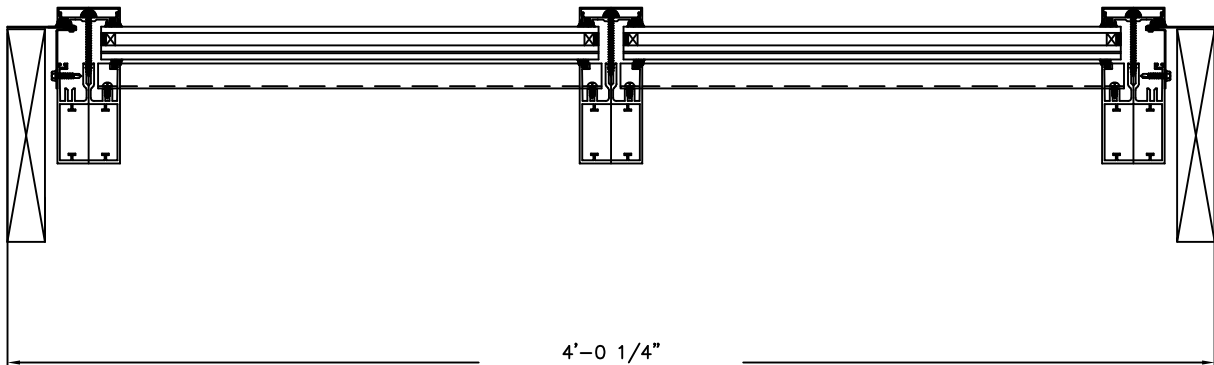

4'-0 1/4"  
OUT TO OUT OF FLASHING

**CROSS SECTION CS-2**

SCALE : 3" = 1'-0"

TEST SPECIMEN COMPLIES  
WITH THESE DETAILS.  
ANY DEVIATION IS NOTED.  
NCTL 110-14358-01  
TEST COMPLETE: 11/18/11

CS-2  
SR-1

OUT TO OUT OF FLASHING  
4'-0 1/4"  
**PLAN VIEW**  
SCALE : 3" = 1'-0"

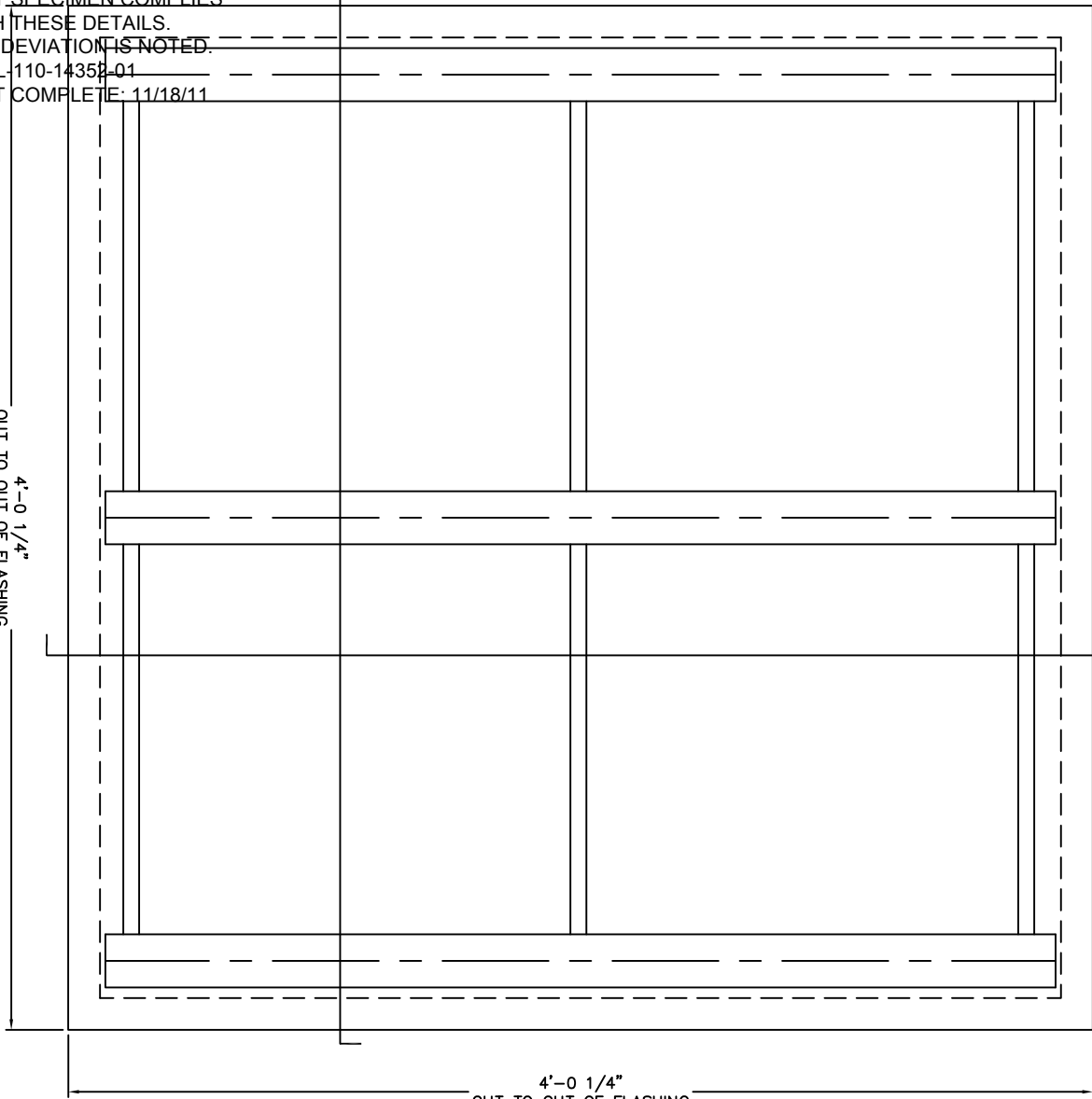

4'-0 1/4"  
OUT TO OUT OF FLASHING

CS-1  
SR-1

**CROSS SECTION CS-1**  
SCALE : 3" = 1'-0"

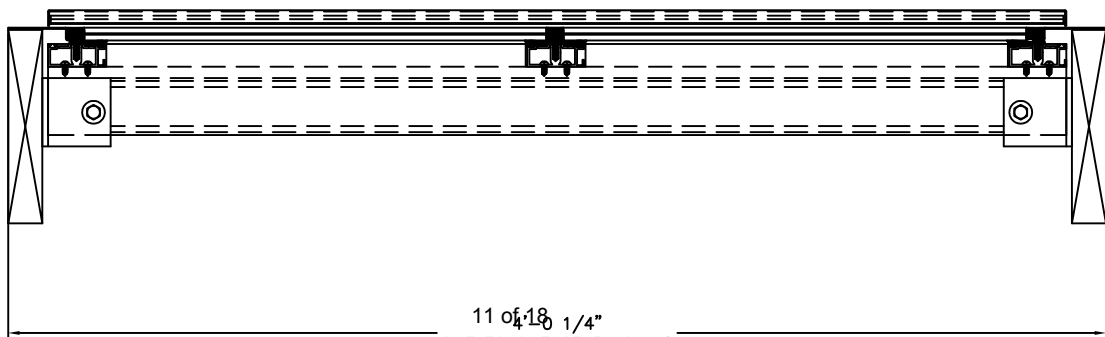

11 of 18 1/4"  
OUT TO OUT OF FLASHING

TEST SPECIMEN COMPLIES  
WITH THESE DETAILS.  
ANY DEVIATION IS NOTED.  
NCTL: 10-14352-01  
TEST COMPLETE: 11/18/11

CS-1  
SK-1

4'-0 1/4"  
OUT TO OUT OF FLASHING

CS-2  
SK-1

4'-0 1/4"  
OUT TO OUT OF FLASHING

**PLAN VIEW**

SCALE : 3" = 1'-0"

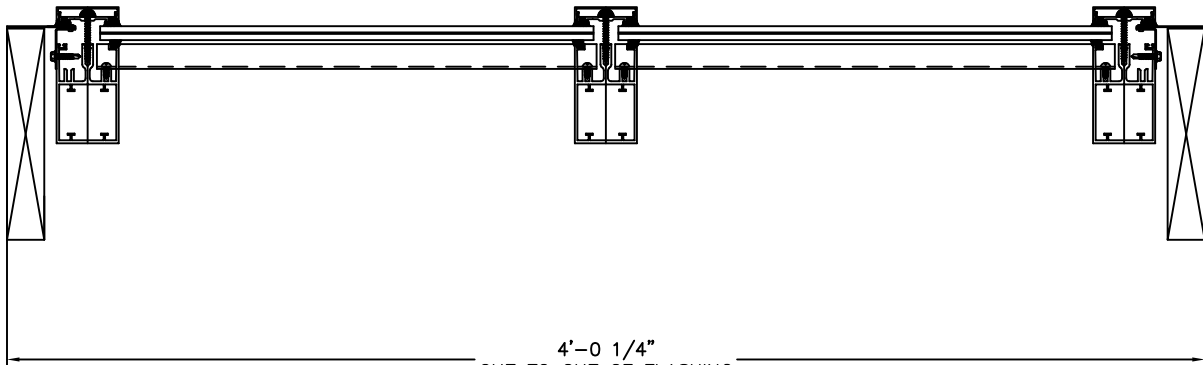

4'-0 1/4"  
OUT TO OUT OF FLASHING

**CROSS SECTION CS-2**

SCALE : 3" = 1'-0"

TEST SPECIMEN COMPLIES WITH THESE DETAILS. ANY DEVIATION IS NOTED. NCTL-110-14352-01 TEST COMPLETE: 11/18/11

TEST SPECIMEN COMPLIES WITH THESE DETAILS. ANY DEVIATION IS NOTED.

REVISION NO. 1  
EST. DATE 11/16/11  
Break All Corners Radius of .015  
Customer's Part Number 69-23-04  
D.S.S. 28909

H-07833  
Title Number  
Design Number

STANDARD COMMERCIAL TOLERANCES FOR EXTRUDED PRODUCTS APPLY UNLESS SPECIFIED OTHERWISE

ACTUAL SIZE

(\*) DENOTES R .125 ( 6 )  
S/H RATIO: 4.286 MAX ALLOWED: 3.500

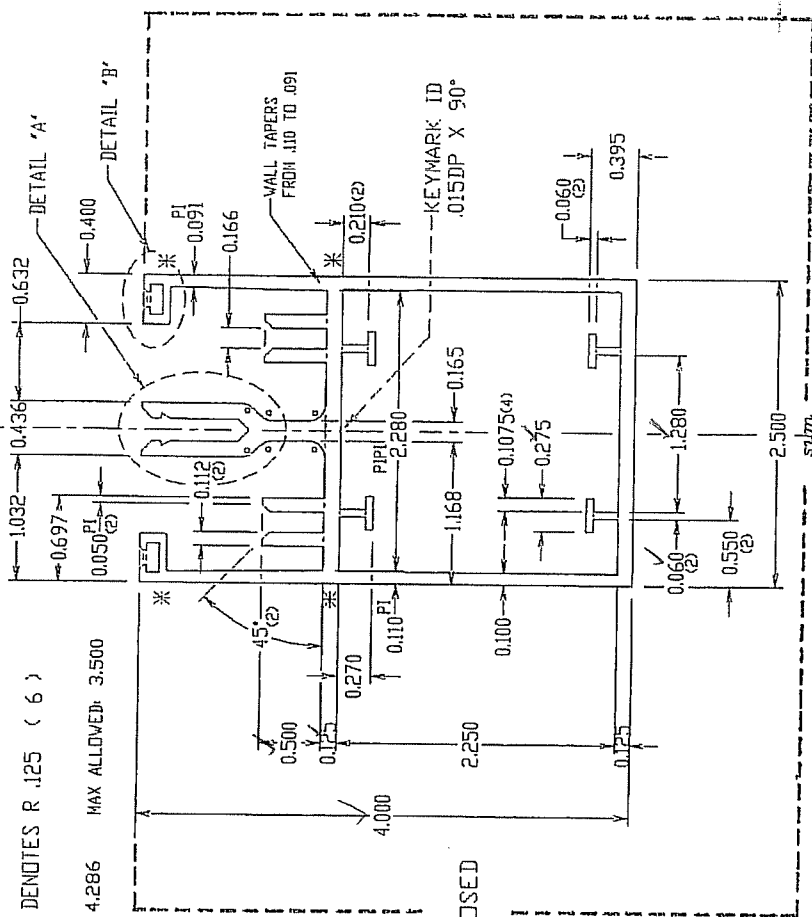

KEYMARK CORPORATION  
FONDA, NEW YORK  
FAX ENG. (518) 853-3435 SALES (518) 853-3130  
TEL. (518) 853-3421 E-MAIL engny@keymarkcorp.com

STRUCTURAL STREAKING IS EXPECTED

"A"  
4:1

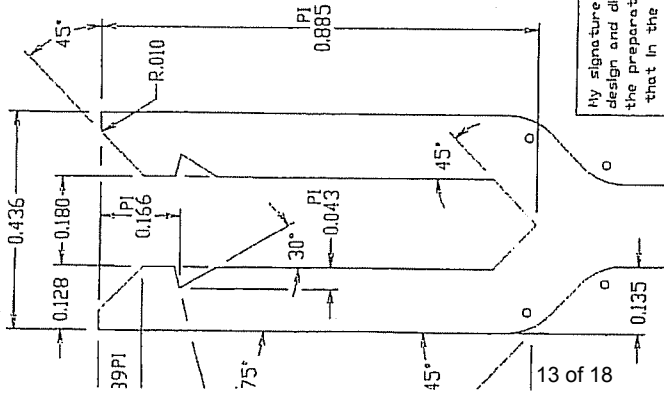

My signature on this print indicates approval of design and dimensions as shown and I authorize the preparation of extrusion die and acknowledge that in the event I do not purchase 25,000 lbs. for solids or 30,000 lbs. for hollows of material within a period of 18 months, that I will pay the cost of making the die, which shall be

Date \_\_\_\_\_  
Signature \_\_\_\_\_

INITIAL HERE FOR ID TYPE/LOCATION APPROVAL

DETAIL "B"  
SCALE 2:1

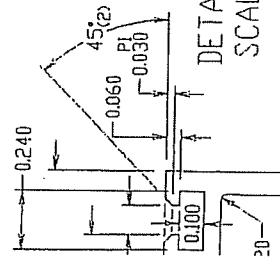

Ly =	Machine	Type: 00
Sy =	C-hp	Factor: 16

Hll  Acc.  Drmr.  Dr-con.

Synl  PRINT CORRECTION  Revisions  Date   
 Solid  Semi-hollow  Class  Hollow  Class 2

TEST SPECIMEN COMPLIES WITH THESE DETAILS. ANY DEVIATION IS NOTED. NCTL-110-14352-01 TEST COMPLETE: 11/18/11

STRUCTURAL STREAKING IS EXPECTED

S-31713 MATES WITH: S-31712

STANDARD COMMERCIAL TOLERANCES FOR EXTRUDED PRODUCTS APPLY UNLESS SPECIFIED OTHERWISE

SEMI-HOLLOW

S-31713  
File Number

ACTUAL SIZE

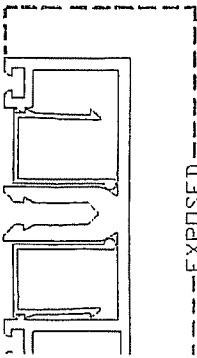

--- EXPOSED ---  
ATID: 3.589 MAX ALLOWED: 3.500

L "A"  
E 8:1  
4 of 18

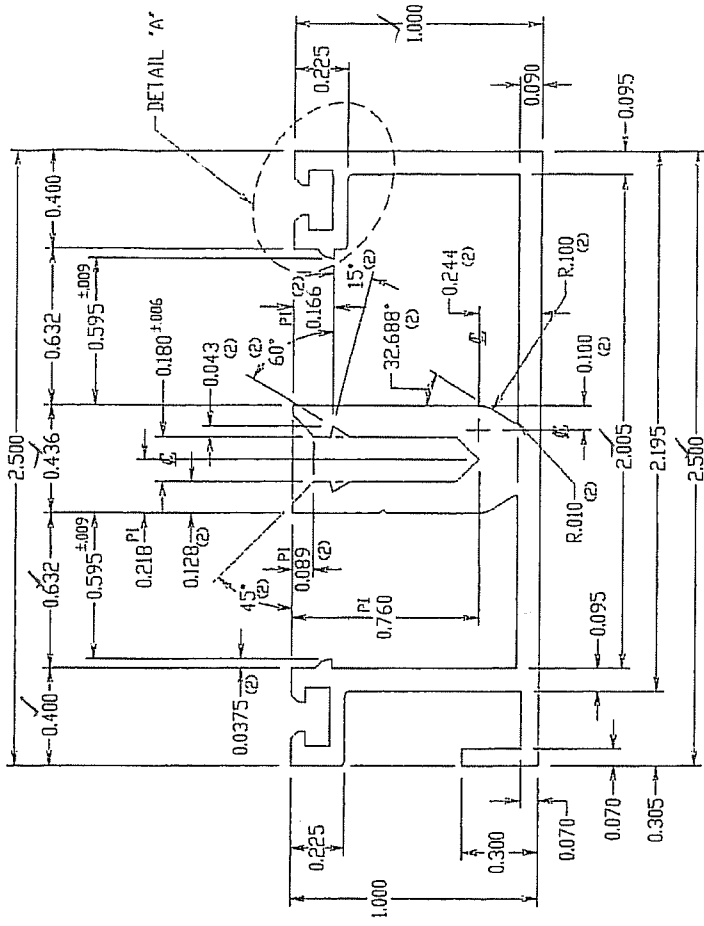
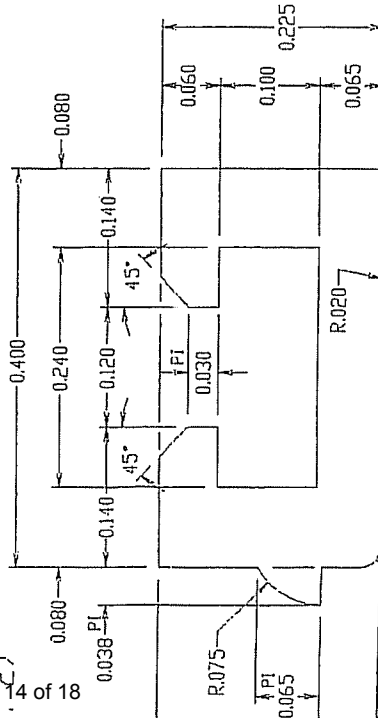

**KEYMARK CORPORATION**  
FOND DU LAC, NEW YORK

FAX ENG. (516) 853-3435 SALES (516) 853-3130  
TEL (516) 853-3421 E-MAIL keyeng@keymarkcorp.com

Unspecified Wall Thickness: AS NOTED	Break All Corners: R.100 (2)
Customer: ACURITE SKYLIGHTS	Customer's Part Number: EST-11-01
Job Name: ACURITE SKYLIGHTS	Scale: 2:1
Part Title: ACURITE SKYLIGHTS	Alloy: 6063
Revisions: PRINT CORRECTION	Est. Area: 0.791 In <sup>2</sup>
Date: 04-21-02	Est. Vt./Ft.: 5.093 In
	Temp: T-5
	Est. Perimeter: 15.021 In
	Cavity Size: 2-3
	Circle Size: 15.021 In
	Exterior Perimeter: 15.021 In
	Class: Hollow
	Drccn: E23

$I_x = 0.080$	$I_y = 0.418$	Factor
$S_x = 0.134$	$S_y = 0.332$	17

COMPLIES WITH THESE DETAILS. ANY DEVIATION IS NOTED. NCTL-110-14352-01 11/16/11

TEST SPECIMEN COMPLIES WITH THESE DETAILS. ANY DEVIATION IS NOTED. NCTL-110-14352-01 TEST COMPLETE: 11/18/11

STANDARD COMMERCIAL TOLERANCES FOR EXTRUDED PRODUCTS APPLY UNLESS SPECIFIED OTHERWISE

STRUCTURAL STREAKING IS EXPECTED

MATES WITH:  
S-08547  
S-08548  
S-14747

ACTUAL SIZE

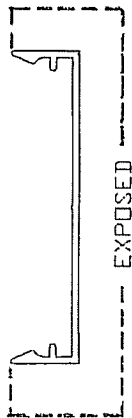
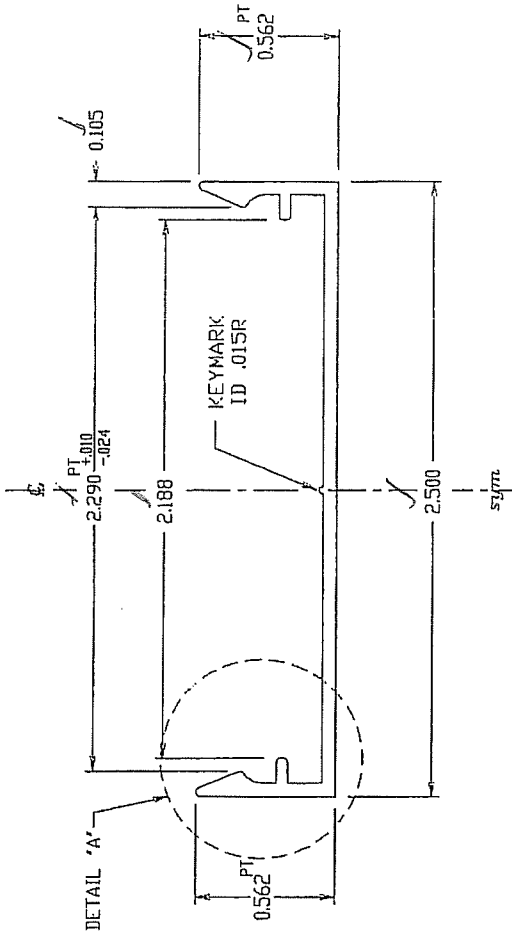

FOR ASSEMBLY REFER TO S-08547

DETAIL "A"  
SCALE 8:1

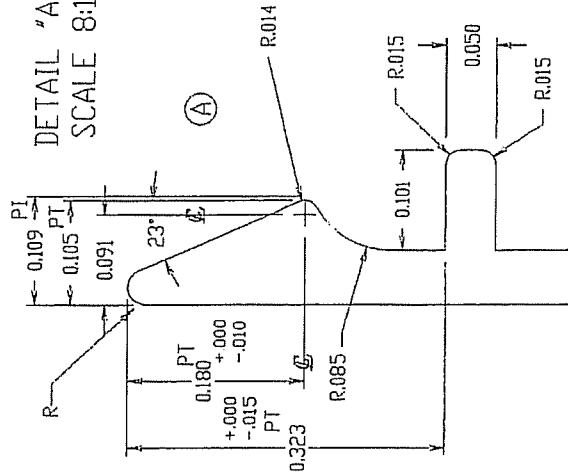

 <p>KEYMARK CORPORATION FONDA, NEW YORK</p>		Unspecified Wall Thickness: .055	Break All Corners .015 Radius or as Noted								
<p>FAX ENG. (518) 853-3435 SALES (518) 853-3130 TEL. (518) 853-3421 E-MAIL keyeng@keymarkcorp.com</p>		Customer: KEYMARK CORPORATION	Customer's Part Number: 252102								
<p>Revisions</p> <table border="1"> <tr> <th>Sym</th> <th>Date</th> </tr> <tr> <td>2</td> <td>05-04-97</td> </tr> <tr> <td></td> <td>11-01-95</td> </tr> <tr> <td>A</td> <td>05-01-91</td> </tr> </table>		Sym	Date	2	05-04-97		11-01-95	A	05-01-91	Job Name: PT-252	Scale: 2:1
Sym	Date										
2	05-04-97										
	11-01-95										
A	05-01-91										
<p>Part Title: .562 SNAP COVER</p>		Est. Area: 0.211 in <sup>2</sup>	Est. Perimeter: 3.520 in								
<p>Alloy: 6063</p>		Temp: T-5	Est. Perimeter: 7.529 in								
<p>Circle Size: 2-3 in</p>		Exterior Perimeter: 7.529 in	Checked: S.J.S.								
<p>Class: <input type="checkbox"/> Solid <input checked="" type="checkbox"/> Semi-hollow <input type="checkbox"/> Hollow</p>											

I <sub>x</sub> = 0.005	I <sub>y</sub> = 0.178	Factor	30	MIL	<input type="checkbox"/>	ANO	<input checked="" type="checkbox"/>	DRRR	<input checked="" type="checkbox"/>	DR-CN	<input checked="" type="checkbox"/>
S <sub>x</sub> = 0.011	S <sub>y</sub> = 0.143										

TEST SPECIMEN COMPLIES WITH THESE DETAILS. ANY DEVIATION IS NOTED. NCTL-110-14352-01 11/16/11

TEST SPECIMEN COMPLIES WITH THESE DETAILS. ANY DEVIATION IS NOTED. NCTL-110-14352-01 TEST COMPLETE: 11/18/11

STANDARD COMMERCIAL TOLERANCES FOR EXTRUDED PRODUCTS APPLY UNLESS SPECIFIED OTHERWISE

STRUCTURAL STREAKING IS EXPECTED

S-35591  
Die Number  
Design Number

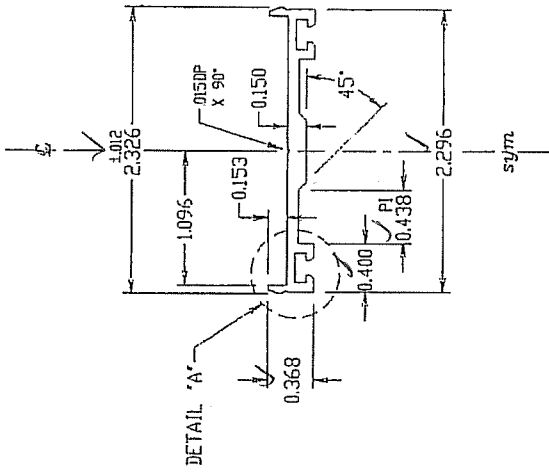

ACTUAL SIZE

NO EXPOSED SURFACES



My signature on this print indicates approval of design and dimensions as shown and I authorize the preparation of extrusion die at the cost of:

\$ 389.00

Date

Signature

TEST SPECIMEN COMPLIES WITH THESE DETAILS. ANY DEVIATION IS NOTED. REPORT NO. NCTL-110-14353-1 TEST DATE 11/16/11

1/16 4:1  
18

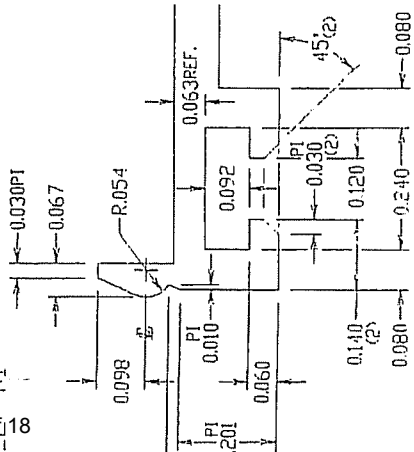

Alloy =  
Temper =  
Cavity Size =  
Circle Size =  
Est. Perimeter =  
Est. Area =  
Finish Perimeter =  
Scale =  
Date =  
Drawn =  
Checked =

Unspecified Wall Thickness	.090	Break All Corners Radius or as Noted	.015
Customer	ACURITE SKYLIGHTS	Customer's Part Number	
Job Name			
Part Title	SKYLIGHT PRESSURE CAP	Scale	1:1
Alloy	6063	Finish Perimeter	In 01-14-04
Temper	T-6	Est. Perimeter	In 6.969
Cavity Size	2.3	Est. Area	In <sup>2</sup> 0.296
		Circle Size	In 2.3
		Est. Perimeter	Lbs 6.969
		Exterior Perimeter	In 6.969
		Checked	

**KEYMARK CORPORATION**  
FONDA, NEW YORK

FAX ENG. (510) 853-3435 SALES (510) 853-3130  
TEL. (518) 853-3421 E-MAIL engny@keymarkcorp.com

PRINT CORRECTION

Svr.	Revisions	Date

Solid  Semi-hollow  Class  Hollow  Class

INITIAL HERE FOR ID TYPE/LOCATION APPROVAL

Appr.  Dmr.  Drcn.

TEST SPECIMEN COMPLIES WITH THESE DETAILS.  
 ANY DEVIATION IS NOTED.  
 NCTL-110-14352-01  
 TEST COMPLETE: 11/18/11

TEST SPECIMEN COMPLIES WITH THESE DETAILS.  
 ANY DEVIATION IS NOTED.  
 REPORT NO. NCTL-110-14353-1  
 TEST DATE 11/16/11

S-38970  
 Design Number

STANDARD COMMERCIAL TOLERANCES FOR EXTENDED PROJECTS APPLY UNLESS SPECIFIED OTHERWISE

UNIFORM PAINT COVERAGE NOT EXPECTED IN THIS AREA

STRUCTURAL STREAKING IS EXPECTED

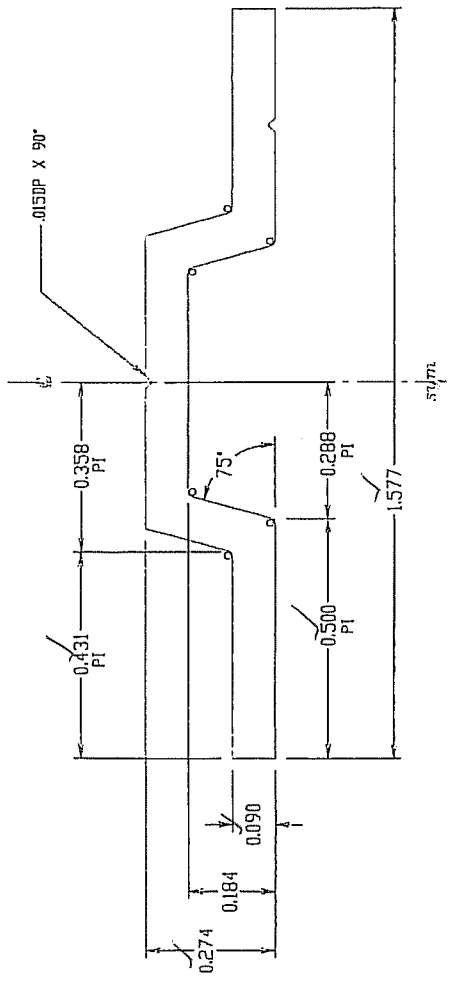

775.90  
 10-11-05  
 H. M. V. M. A. M.



( ) DENOTES R .010 ( 6 )

KEYMARK CORPORATION  
 FONDA NEW YORK  
 FAX ENG (516) 653-3435 SALES (516) 653-3130  
 TEL (516) 653-3421 E-MAIL engny@keymarkcorp.com

Unspecified Mill Thickness	.080	Break Est Corners	.010
Customer's Part Number	ACRULITE SKYLIGHTS	Break Est Pad	or as Noted
Part Title	STRUCTURAL SEAL	Customer's Part Number	
Alloy	6063	Scale	4:1
Temp	T-5	Est Diameter	3.500
Coating		Est Diameter	3.910
		Est Diameter	3.910
		Scale	1.6

INITIAL HERE FOR ID TYPE/LOCATION APPROVAL

Material	Aluminum	Type	00
Temp		Factor	20

Print Correction	Revisions	Date



TEST SPECIMEN COMPLIES  
WITH THESE DETAILS.  
ANY DEVIATION IS NOTED.  
NCTL-110-14352-01  
TEST COMPLETE: 11/18/11

TEST SPECIMEN COMPLIES  
WITH THESE DETAILS.  
ANY DEVIATION IS NOTED.  
REPORT NO. NCTL-110-14353-1  
TEST DATE 11/16/11

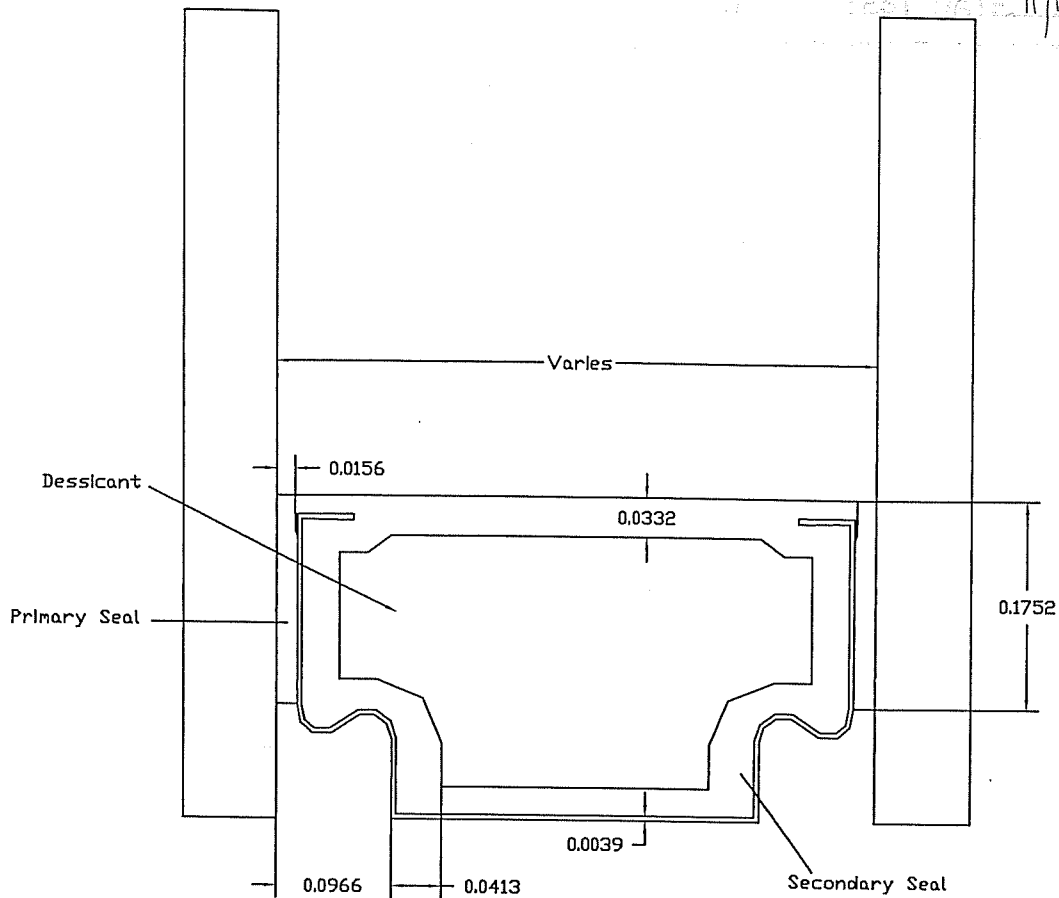

### Technoform

Spacer Dimensions -Fill dimensions where applicable - Please fill out a spacer sheet for each spacer used whether spacer type or size.

Primary Seal	Secondary Seal	Material	Fill
<input checked="" type="checkbox"/> Butyl	<input checked="" type="checkbox"/> Butyl	<input type="checkbox"/> Aluminum	<input checked="" type="checkbox"/> Dessicant
<input type="checkbox"/> PIB	<input type="checkbox"/> PIB	<input type="checkbox"/> Steel - Mild	<input type="checkbox"/> Air
<input type="checkbox"/> Polysulphide	<input type="checkbox"/> Polysulphide	<input checked="" type="checkbox"/> Steel - Stainless	<input type="checkbox"/> Other _____
<input type="checkbox"/> Silicone	<input type="checkbox"/> Silicone	<input type="checkbox"/> Steel - Galvanized	
<input type="checkbox"/> Urethane	<input type="checkbox"/> Urethane	<input type="checkbox"/> Vinyl	
<input type="checkbox"/> None	<input type="checkbox"/> None	<input type="checkbox"/> Foam _____	
<input type="checkbox"/> Other _____	<input type="checkbox"/> Other _____	<input type="checkbox"/> Other _____	